

Vinkøleskab

Betjeningsvejledning

CC145SB-SE

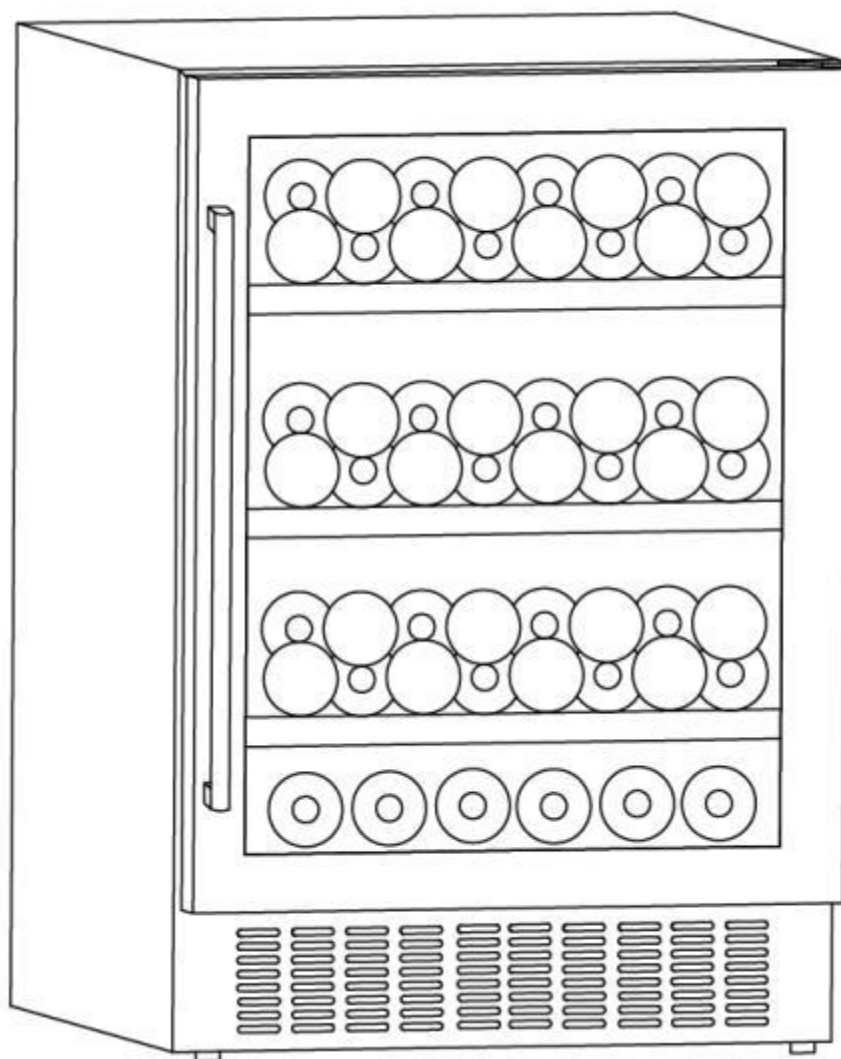

Tak for dit køb af dette CaveCool vinkøleskab. Dette produkt er til køling af vin.

www.cavecool.com



Indhold

Sikkerhed og advarsler	1-2
Installation	3
Beskrivelse af apparatet	4-5
Betjening.....	6-8
Problemløsning.....	9
Vedligehold og rengøring.....	10
Tekniske specifikationer.....	11

Sikkerhed og advarsler

Din sikkerhed er yderst vigtig for vores firma. Venligst læs denne vejledning inden du tager apparatet i brug. Skulle du være tvivl om nogle informationer i denne vejledning, venligst kontakt os.



Forbud



Advarsel



Bemærk



Bemærk

- Dette apparat bør ikke betjenes af børn. Børn må ikke lege med apparatet, da det kan være forbundet med fare.
- Dette apparat er beregnet til brug i private hjem og ikke til professionel eller industrielt brug.



Advarsel

- Hold ventilationsåbninger frie på apparatet og udluftning fri ved indbygning.
- Af sikkerhedsmæssige årsager og for at sikre vinkøleskabets optimale funktion skal alle vinkøleskabe have jordforbindelse og stå i perfekt vater på alle ledder og kanter.
- Brug ikke mekaniske apparater eller andre redskaber for at gøre afrimning og optøning hurtigere.
- Ødelæg ikke kølerør og lignende.
- Benyt ikke elektriske apparater inden i skabet.
- Apparatet må kun tilsluttes strøm i.h.t. til rating label på siden eller bagsiden af apparatet.
- Tilslut apparatet til 220-240 V / 50 Hz vekselstrøm via en korrekt installeret stikkontakt med jordforbindelse.

Stikkontakten skal være sikret med en 10 -13 A sikring. Vinkøleskabet leveres med en såkaldt Schuko stikprop som er standarden i de fleste lande i Europa. Dette er en 2-benet stikprop med sidejord.

Mange danske hjem har en stikkontakt med dansk jord (3 ben). I de tilfælde skal du tilkøbe en adapter hos din forhandler, som nemt klikkes på.

Alternativt skal du eller en autoriseret elinstallatør skifte stikproppen til den danske 3-benede stikprop som du ligeledes kan købe hos din forhandler.

- Stikket bør være nemt tilgængeligt i tilfælde nødstop.
- Opbevar ikke benzin, brandbare væsker, og lignende indeni eller i nærheden af apparatet.

Børnesikkerhed

- Tillad ikke børn at lege inden i skabet, da de kan blive spærret inde.
- Tillad ikke børn at lege med eller hænge på døren, da skabet kan vælte.
- Tillad ikke børn at røre ved kompressor eller andre ting under skabet pga. fare.

Vinkøleskabet tåler ikke vand

- Sprøjt eller hæld ikke vand i skabet, da det kan kortslutte og det skaber risiko for elektrisk chok.

Pas på fryseskader

- Rør ikke ved de indvendige flader med våde hænder, da det kan give fryseskader.

Åbn ikke døren i længere tid

- Hvis døren er åben i lang tid vil det påvirke skabets køleevne.

Modificer ikke skabet

- Lav ikke konstruktionsændringer på skabet, da det kan ødelægge apparatet.

Sluk for strømmen og træk stikket ud hvis:

- Sluk for strømmen og træk stikket ud før rengøring og vedligehold.
- Træk stikket ud i tilfælde af strømsvigt i huset eller området.

Bortskaffelse af apparatet

- Skal afleveres på den nærmeste genbrugsplads
- Før du smider apparatet ud bør døren afmonteres, så børn ikke leger med apparatet.



FORBUD

Lav ikke skader på ledningen





- Træk ikke stikket ud ved at hive i ledningen, men kun ved at trække stikket ud.
- Stil ikke apparatet oven på ledningen.
- Rul ledningen sammen når skabet flyttes for at undgå skader.

Hvis ledninger er skadet

- Brug ikke ledningen hvis den er skadet, få en ny monteret af autoriseret montør.

Installation

Position

-  Ved flytning af apparatet bør det ikke vippes over 45°.
-  Apparatet skal placeres på et fladt, fast og tørt gulv eller lignende ikke-brændbart underlag. Brug ikke indpakningens flamingo. **VÆR OPMÆRKSOM PÅ, AT DU IKKE BØR INDBYGGE ET VINKØLESKAB PÅ GULV MED GULVVARME, DA DETTE KAN PÅVIRKE VINKØLESKABETS FUNKTIONALITET.**
-  Placer ikke apparatet i et fugtigt rum.
-  Placer ikke apparatet i et rum, der ikke er frostfrit.
-  Placer ikke apparatet udendørs.

Dette vinkøleskab er designet til indbygning eller som fritstående

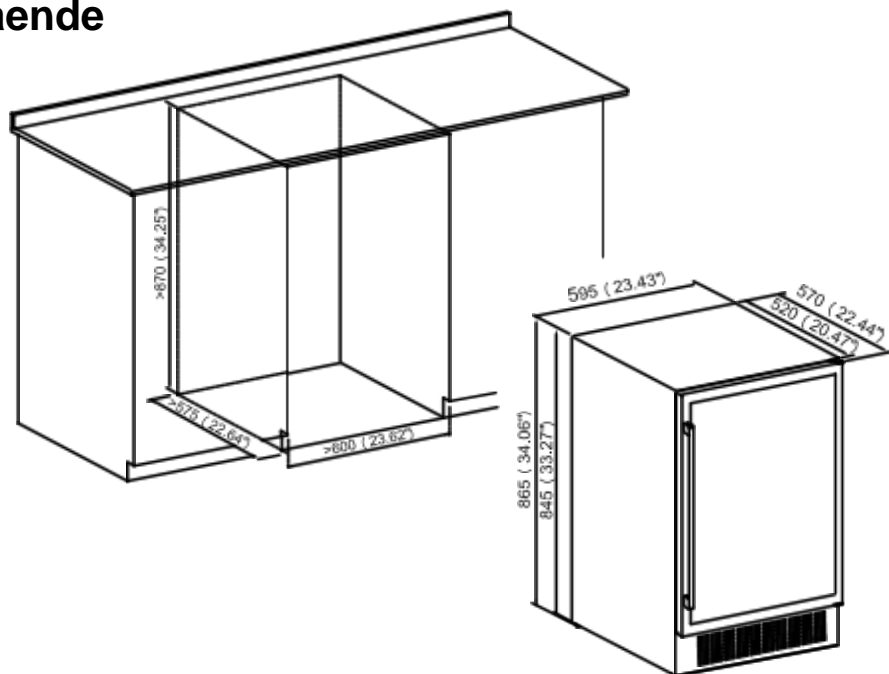

Vinflasker kan opbevares i skabet, så snart du kan mærke køling i skabet, efter ca. 1 time.

Beskrivelse af apparatet

Tilbehør og navne

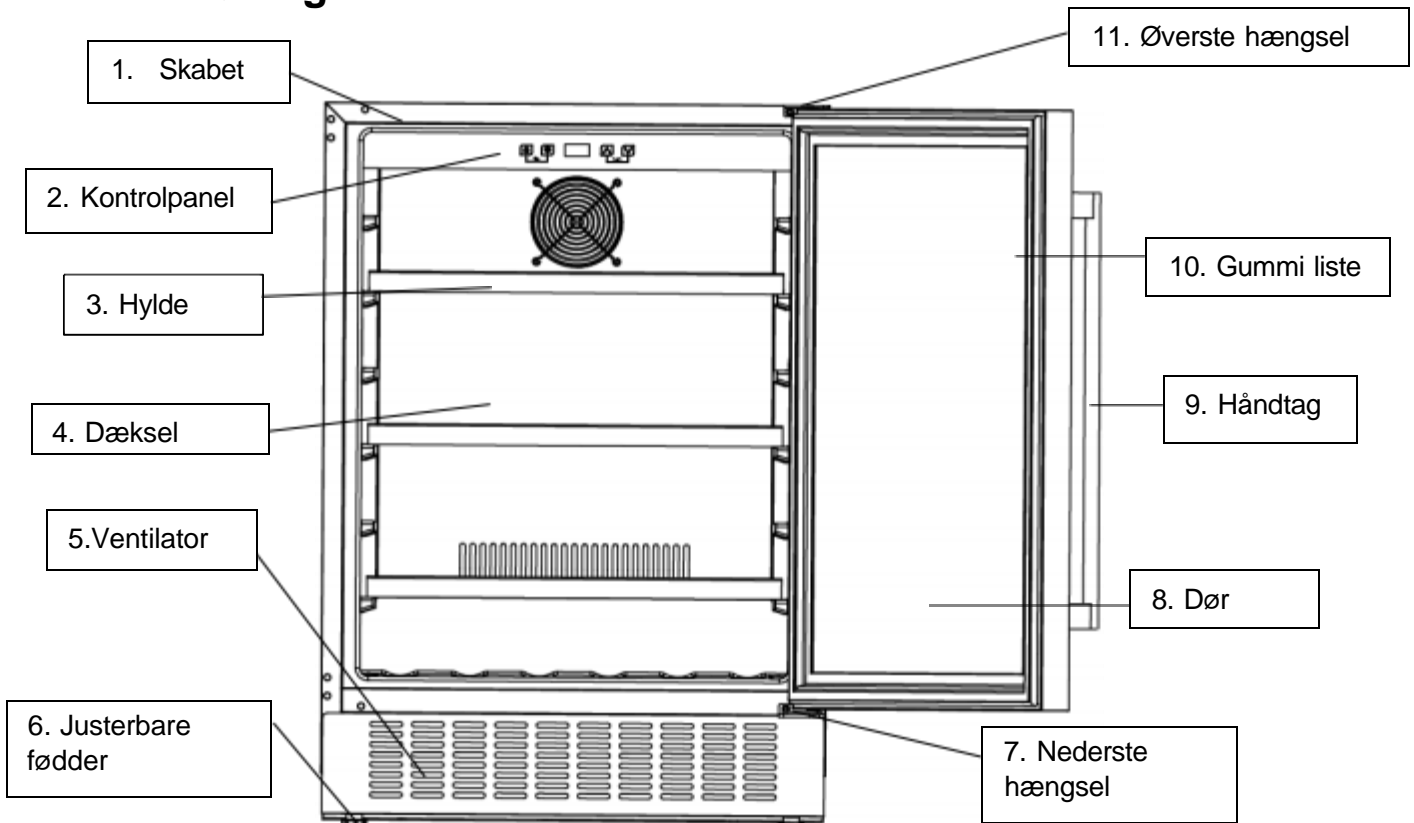

Note: Hylde, dørramme, håndtag og andre dele kan være forskellige på forskellige modeller. Alle foto og tegninger i denne manual er kun for reference.

Installation af dørhåndtag og vending af døren

1. Monter håndtaget på dørrammen.

Håndtaget følger med i en separat pakke med skruer og ligger i skabet.

- ① Ved at trække et lille stykke af gummilisten fri, kan man se 2 små skruehuller i dørrammen
- ② Sæt skruerne i hullerne indefra og monter håndtaget på ydersiden af døren
- ③ Stram skruerne med en skruetrækker
- ④ Sæt gummilisten på plads igen.

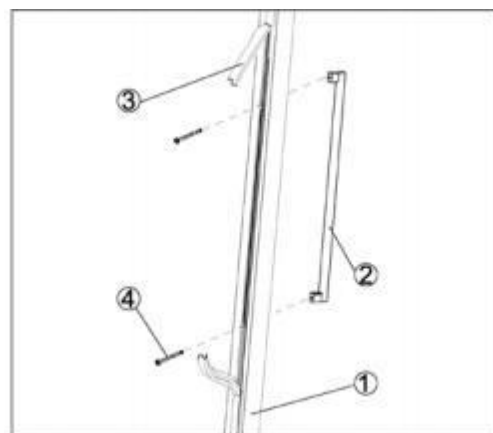

2. Vending af døren
3. Vinkøleskabet er leveret med åbning fra venstre til højre. For at vende åbningsretningen:

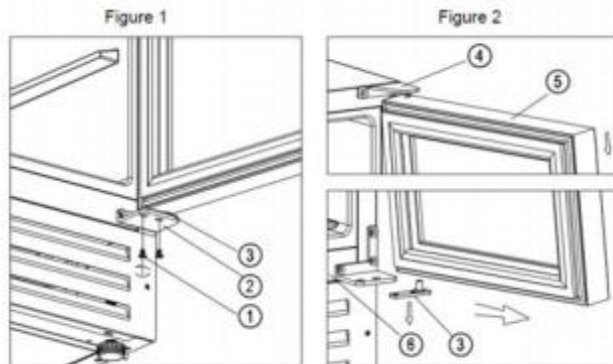

- ❖ Åben døren 90 grader og hold den stille.
- ❖ Løsn de 2 skruer ① på de nederste højre hængsel ② [Figur 1].
- ❖ Frigør døren ⑤ forsigtigt mens døren holdes [følg retningen på figur 2] så du kan frigøre det nederste hængsel ② og fortsæt med at trække døren ⑤ langsomt nedad indtil du kommer af det øverste hængsel ④, og fjern det nederste hængsel ③ fra dørhullet [Figur 2].
- ❖ Afmontere øverste højre hængsel ④ og nederste hængsel ② fra kabinettet ⑥ og gem hængslerne til hvis du i fremtiden skal vende døren igen.[Figur 3]

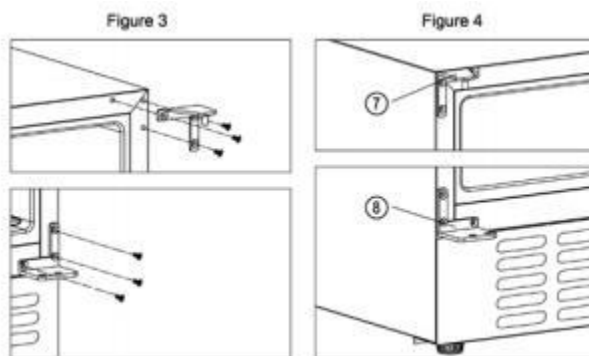

- ❖ Montere nederste venstre hængsel på kabinettet ⑧. Hængsel ⑦ og ⑧ ligger i en plastikpose som medfølger skabet.[Figure 4]
- ❖ Drej døren ⑤ 180 grader og sæt den forsigtigt på det nederste hængsel ③ hvor tappet på hængslet skal ind i dørhullet. Sæt det øverste venstre hængsel på døren og fastgør til kabinettet ⑦ Samtidigt med at du holder døren stabil og strammer skruerne. Vending af døren er nu foretaget.

Betjening

Start operation

Opstart

1. Rengøring af skabet

Før strømmen tilsluttes bør apparatet rengøres. (For detaljer, se “Vedligehold og Rengøring”)

2. Placering

Før skabet tilsluttes strøm, bør det stå i mindst 30 minutter.

3. Tilslut og Tænd

Apparatet vil starte nedkøling som tager ca. 1 time inden det kan mærkes.

Kontrolpanel



Alle knapper virker ikke hvis skabe er i “Låst mode”. Husk at låse op først.



Tænd / Sluk

1. Hold knappen inde i 3 sekunder, for at tænde.
2. Hold knappen inde i 3 sekunder for at slukke.



Lys

Tryk på knappen, for at tænde eller slukke Led lyset inde i skabet.



OP

Tryk på knappen en gang, LED Display blinker og viser den faktiske temperatur. Fortsæt med at trykke for at justerer den ønskede temperatur, et tryk øger temperaturen med 1°C. Efter 5 sekunder uden tryk på knappen holder displayet op med at blinke og den ny temperatur er sat. LED displayet viser nu den faktiske temperatur i skabet.



NED

Tryk på knappen en gang, LED Display blinker og viser den faktiske temperatur. Fortsæt med at trykke for at justere den ønskede temperatur, et tryk sænker temperaturen med 1°C. Efter 5 sekunder uden tryk på knappen holder displayet op med at blinke og den ny temperatur er sat. LED displayet viser nu den faktiske temperatur i skabet.



Børnelås (Kombinationsknapper)

- 1、Lås: Tryk begge knapper samtidigt i 3 sekunder for at låse.
- 2、Lås op: Tryk begge knapper samtidigt i 3 sekunder for at låse op.

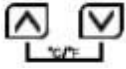

Fahrenheit/Celsius display Skift

Skift temperaturvisning i displayet mellem Fahrenheit og Celsius ved at trykke på begge knapper.



Bemærk

1. Produktet er indstillet til 12°C fra fabrikken. Den korrekte temperatur til den enkelte vin skal indstilles af brugeren.
2. Temperaturen kan justeres fra **5 til 20°C**.
3. Alarm lyd: Hvis systemet svigter vil en alarm lyde. Tryk på en vilkårlig knap på kontrolpanelet for at annullere lyden.
4. Temperatur sensor svigt:
Hvis en temperatur sensor svigter, vil displayet vise E1 for midlertidig fejl; E2 for kortslutning.

Opbevaring af vin

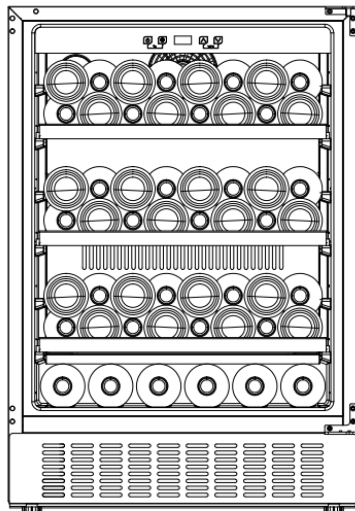

16 bottles

16 bottles

16 bottles

6 bottles

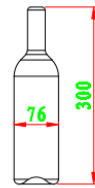
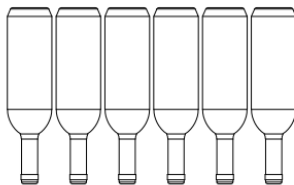
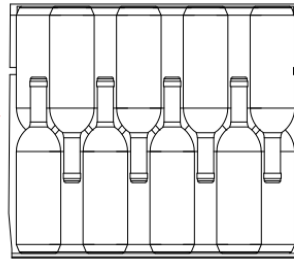

Standard Bordeaux bottle

- ❖ Dette vinkøleskab har individuelle hylder til opbevaring af din vin, stille og roligt uden at flasken skal flyttes hele tiden.
- ❖ ❖ 3 træhylder kan opbevare: **54 bottles.** flasker. (standard Bordeaux 750ml)

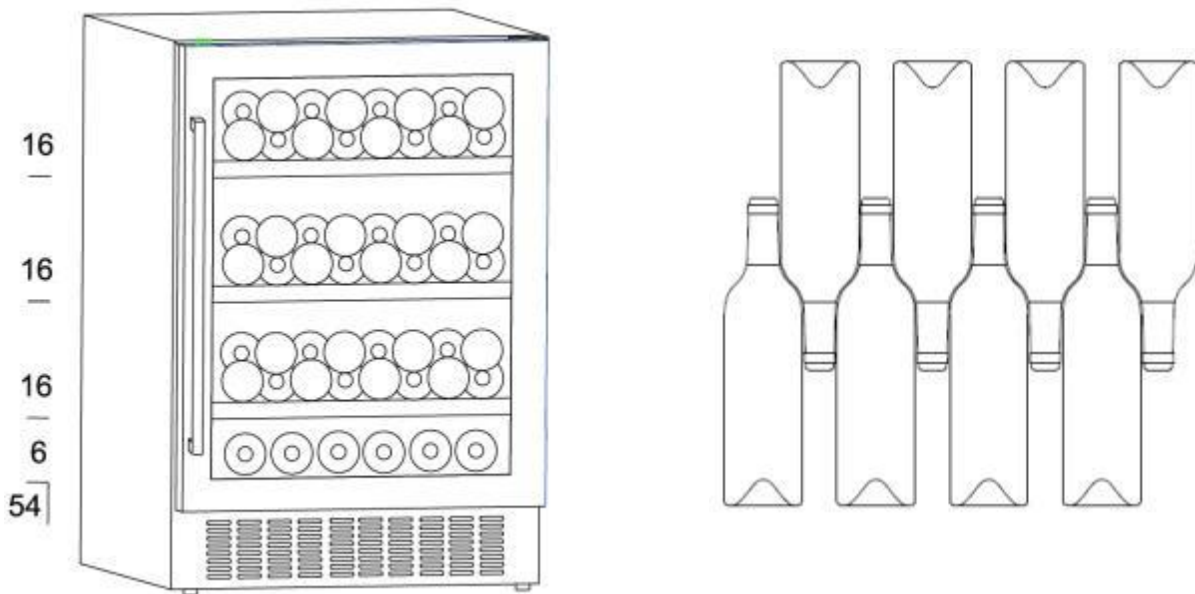

- ❖ Opbevaringskapacitet kan variere i.h.t. flaskernes placering og størrelser.
- ❖ Hver hyld er designet to 1 eller 2 lag af flasker. Mere end 2 lag af flasker per hylder kan ikke anbefales.
- ❖ Hver hyld kan trækkes delvis ud for nemmere adgang.
- ❖ Undgå at blokerer ventilatoren med genstande, da det vil skade køle evnen.
- ❖ Åbn døren helt op inden hylderne trækkes ud.
- ❖ Skemaet nedenfor viser de anbefalede temperaturer for vinopbevaring.

Rødvin	15-18°C
Hvidvin	9-14°C
Rosévin	10-11°C
Champagne og mousserende	5- 8°C

Problemløsning

Apparatet larmer meget	<ul style="list-style-type: none"> • Juster de forreste fødder, for at holde apparatet i vatter/lige • Undgå at apparatet rører ved væggen bag.
Væske lyd indefra skabet	<ul style="list-style-type: none"> • Dette er normal medens apparatet kører
Apparatet kan ikke starte	<ul style="list-style-type: none"> • Forvis dem om at stikket er sat i og strømmen tændt • Kompressoren vil auto starte efter 5 minutter efter strømsvigt
Kompressoren kører hele tiden	<ul style="list-style-type: none"> • Hvis der ikke producers kulde skal der ringes efter service
Dør gummiliste slutter ikke tæt	<ul style="list-style-type: none"> • Efter lang tids brug kan gummilisten blive stiv og ude af facon. 1. Opvarm gummilisten med varm luft blæser eller et varmt håndklæde.
Apparatet køler ikke effektivt	<ul style="list-style-type: none"> • Juster temperature på displayet • Hold apparatet væk fra sollys og varmekilder. • Åbn ikke døren konstant.
Ubehagelig lugt inde i skabet	<ul style="list-style-type: none"> • En smule plastik lugt i nye apparater er normalt og vil forsvinde efter et stykke tid. • Rengør apparatet og udluft det i et stykke tid
Kondensvand på glas døren	<ul style="list-style-type: none"> • Åbn ikke døren konstant, lad den være lukket i længere tid. Sæt ikke temperature for lavt • Høj temperatur og luftfugtighed i omgivelserne skaber også kondens i skabet
Lyset virker ikke?	<ul style="list-style-type: none"> • Forvis dem om stikket er sat i og strømmen tændt. • Ring efter service hvis lyset er itu

Vedligehold og rengøring

Rengøring

- Sluk for strømmen og træk stikket ud inden rengøring begyndes.
- Rens apparatet med en fugtig klud eller svamp med vand.
- Brug ikke rengøringsmidler, opvaskemiddel, kogende vand, vaskepulver eller lignende.
- Skyl ikke apparatet hverken indvendigt eller udvendigt.

Nedenstående vil ødelægge overflade på apparatet:

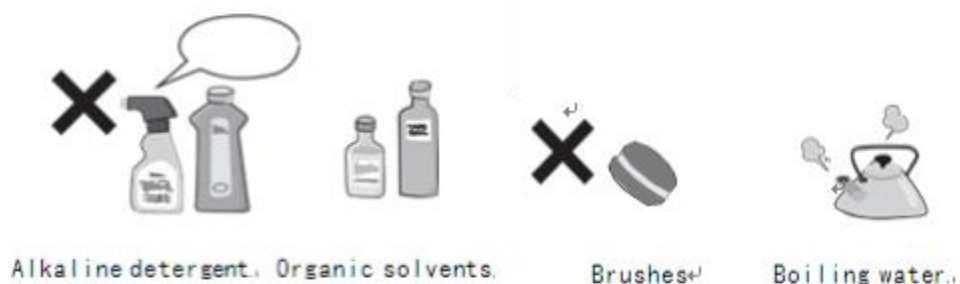

Strømsvigt

De fleste strømsvigt ophører efter kort tid. For at beskytte vinen i tilfælde af strømsvigt bør du undgå at åbne døren.

Ude af brug i længere tid

Fjern alle flasker fra apparatet, sluk apparatet og træk stikket ud, defrost, rengør skabet og lad døren stå åben for udluftning.



Hvis apparatet slukkes eller der er strømsvigt, vent venligst 5 minutter inden genstart.

Flytning af apparatet

- Sluk for strømmen og træk stikket ud
- Fjern alle flasker.
- Under flytning må apparatet ikke tippes/ hælde mere end 45°.

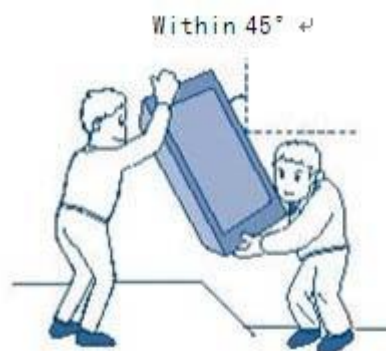



Tekniske specifikationer

Product model	CC145SB-SE
Volt/frekvens	220-240V ~ /50Hz
Kølemiddel/vægt	R600a/35g
Effektiv volume	135 L
Flaske kapacitet	54 flasker
Nettovægt	42 kg
Skabets størrelse (BxDxH)	595×570×865mm
Pakke størrelse (BxDxH)	660×625 x 925 mm

Bemærk :

1. Nettovægten er inklusiv hylder og størrelse er uden håndtag monteret.
2. Yderligere oplysninger ses på siden eller bagsiden apparatets label
3. Flaskekapacitet kan variere alt efter antal hylder og flaske størrelser (standard Bordeaux with 750ml er brugt her).



Wine Cooler Instruction Manual

CC145SB-SE

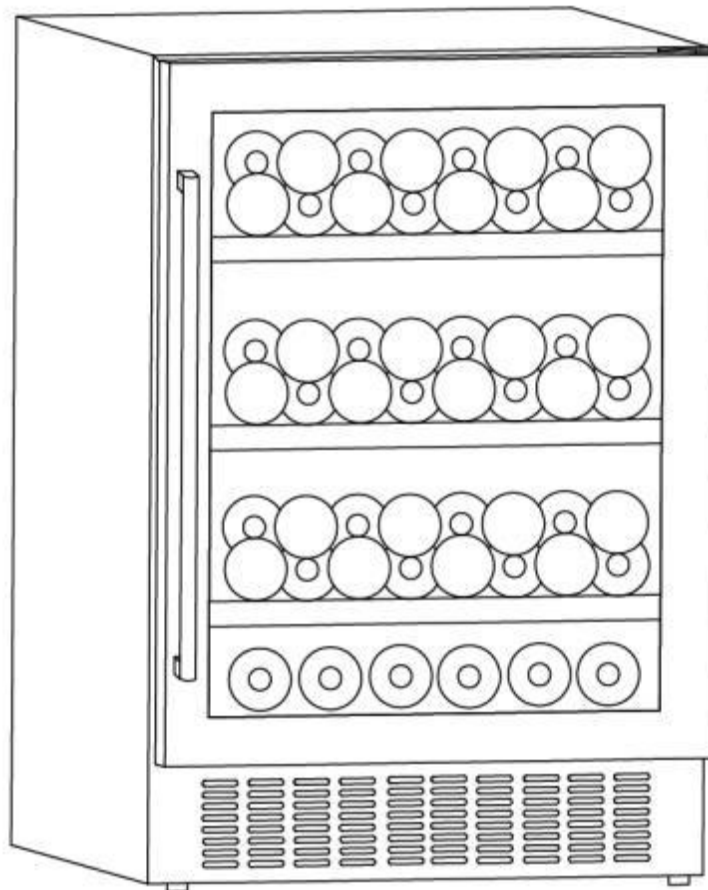

Thank you for buying this CaveCool wine cooler. This product is used to chill wine.



Content

Safety instructions & warnings.....	1-2
Installation.....	3
Description of the appliance.....	4-5
Operation.....	6-9
Troubleshooting.....	10
Maintenance and cleaning.....	11
Technical parameters.....	12

Safety instructions & warnings

Your safety is of the utmost importance to our company. Please make sure that you read this instruction booklet before attempting to install or use the appliance. If you are unsure of any of the information contained in this booklet, please contact the Technical Department.



Prohibition



Warning



Caution



Caution

- This appliance can be used by children aged from 8 years and above and persons with reduced physical, sensory or mental capabilities or lack of experience and knowledge if they have been given supervision or instruction concerning use of the appliance in a safe way and understand the hazards involved. Children shall not play with the appliance. Cleaning and user maintenance shall not be made by children without supervision.
- Children should be supervised to ensure that they do not play with the appliance.
- This appliance is intended for HOUSEHOLD USE ONLY and not for commercial or industrial use.



Warning

- Keep ventilation openings, in the appliance enclosure or in the built-in structure, clear of obstruction.

- Do not use mechanical devices or other means to accelerate the defrosting process, other than those recommended by the manufacturer.
- Do not damage the refrigerant circuit.
- Do not use electrical appliances inside the storage compartments of the appliance, unless they are of the type recommended by the manufacturer.
- Make sure that the appliance is connected to power supply in accordance with the rating label.
- Use an independent grounded socket with 10A or higher, do not connect to transformer or socket with multiple outlets.
- Make sure socket is grounded properly and do not modify power cord & plug.
- For safety reasons and to ensure the optimum functionality of the wine cooler it's important that you connect your wine cooler using an earth/ground connection plug and keep the wine cooler perfectly plumb and level.
- Connect power plug with socket firmly in case of possible risk of fire.
- Plug should be within reach for easy disconnection after the appliance

positioned in case of accidents occurred.

- Do not store or burn gasoline or other inflammables near the appliance in case of possible fire.
- Do not store inflammables, explosives, acid & alkaline liquids etc. in the compartment of the appliance.
- Do not operate other appliances in the compartment.

Child Safety

- Do not allow child play inside the appliance in case of entrapment.
- Do not allow child hang on the door to play in case of falling of the appliance.
- Do not allow child reach into compressor compartment or touch metal components at rear of the appliance in case of possible injury.

Keep away from water

- Do not spray water on the appliance or wash the appliance by pouring or filling water in case of invalid insulation and possible electric shock.

Be careful of freezing

- Do not touch surface of the liner inside the compartment, especially with wet hand, in case of frozen injury while the appliance is in operation.

Do not open the door for long periods

- Opening the door for long periods can cause a significant increase of the temperature in the compartments of the appliance.

Modification on the appliance not allowed

- Do not reconstruct the appliance by yourself which might cause damages to the appliance.

Unplug the appliance under certain conditions

- Unplug the appliance before cleaning & maintenance.
- Unplug the appliance when power cut occurred.

Disposal of the appliances

- Please according to local regulations regarding disposal of the appliance for its flammable refrigerant and blowing gas.
- Before you scrap the appliance, please take off the doors to prevent children trapped.
- Send the appliance to the designated disposal location.



Do not damage the power cord

- Do not disconnect the appliance by pulling power cord rather than pulling the plug.
- Do not set the appliance above the power cord or step on the cord intentionally.
- Put the power cord at right place when moving the appliance.

When the power cord is damaged

- Do not use damaged power cord, and get it replaced immediately by manufacturer service agent or by qualified electrician.
- If needed, extend the power cord with cord of 0.75mm² or bigger by qualified electrician.

Installation

Position

- ⚠ Do not lean the appliance over 45° when moving it to position.
- ⌚ The appliance must be put on flat, firm & dry floor or similar noncombustible pad; do not use the package foam pad .DON'T PALCE A BUILT-IN WINE COOLER ON A HEATED SURFACE SUCH AS HEATED FLOORING,AS THIS WILL AFFECT THE COOLING FUNCTION
- ! Do not put the appliance in the wet place.
- ⊘ Do not use the appliance in the frozen place.
- ⊘ Do not use the appliance outdoor in case of sunlight or rain.

The appliance is designed to either build under the counter or stand alone on the floor.

Demonstration for building under the counter:

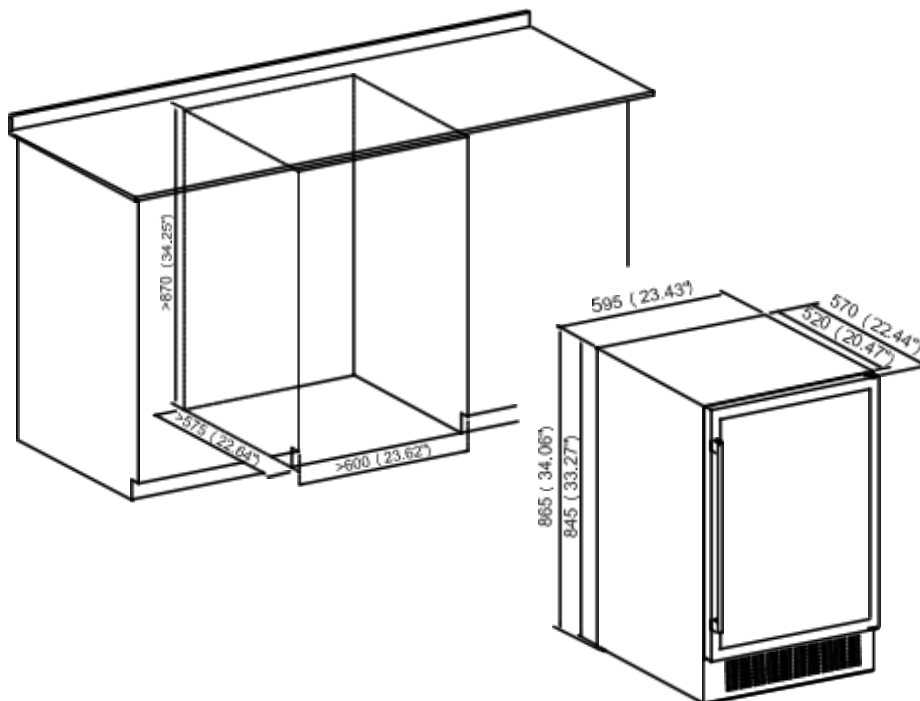

Wine bottles could be stored when you feel cooling inside after the appliance operates around 1 hour.

Description of the appliance

Accessories & name

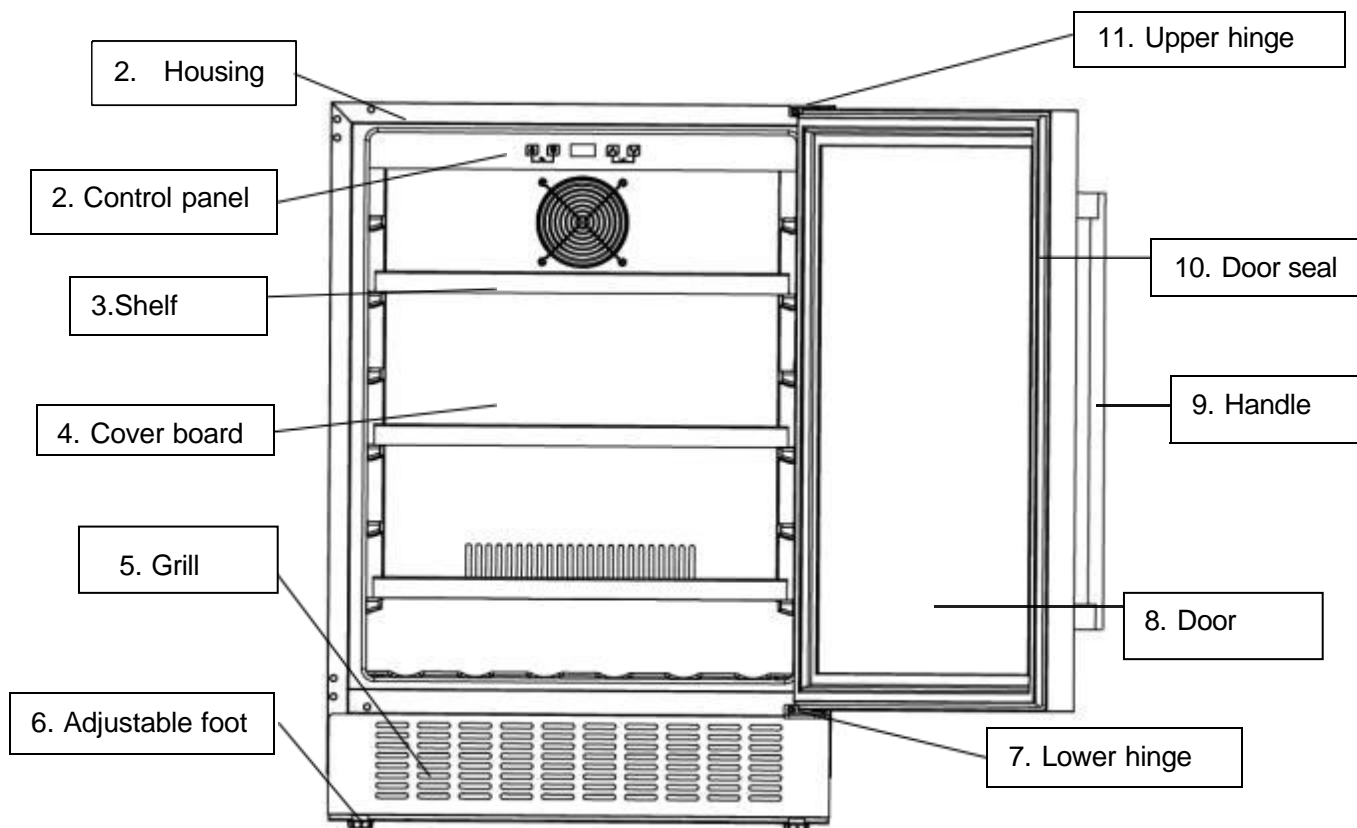

Note: Shelves, door frame, handle and other accessories could be different according to different models and configuration. All photos in this manual are for reference. The appliance you buy might not be exactly the same as shown here. Please refer to the actual product.

Installing the handle and reversing the door of wine cooler

4. Install handle to the door frame of the appliance.

The handle is delivered in a separated package with screws together inside the carton.

- ① Reveal two small holes on the door frame from inner side by pulling out a bit the door seal
- ② Aim the handle to the holes and insert the screws from inside
- ③ Screw them up with screw-driver
- ④ Put back door seal to cover the screws.

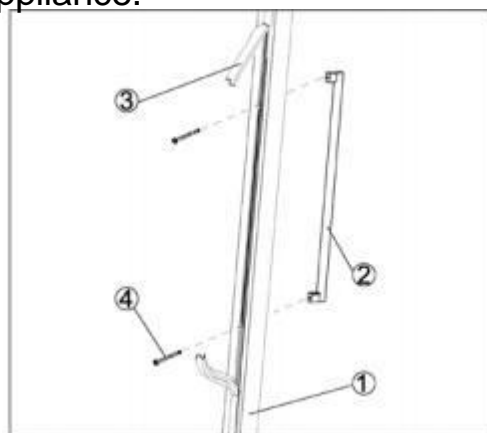

5. Reversing the door

Our wine cooler is delivered with the door opening from left to right. To reverse the opening direction:

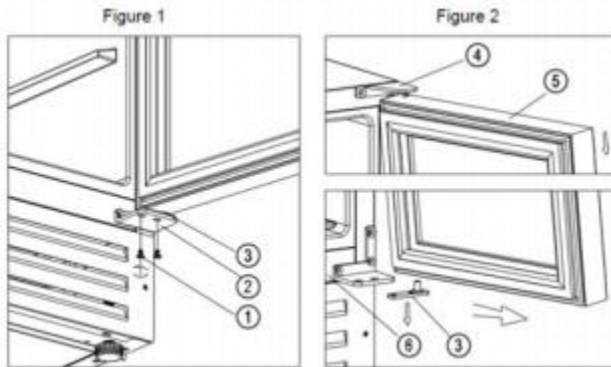

- ❖ Open the door at 90 degrees and keep it steady.
- ❖ Unscrew the two screws① from the right lower hinge②[Figure 1].
- ❖ Pull the door⑤ outwards slowly [follow the arrow direction in Figure 2] to get off the lower hinge② and continue to pull the door⑤ downwards slowly until getting off from the top right hinge④, and take off the lower hinge plate③ from the door axis hole[Figure 2].
- ❖ Screw top right hinge④& right lower hinge② off from the cabinet⑥ and keep them in the polybag for needs if you want to change back left opening door in the future.[Figure 3]

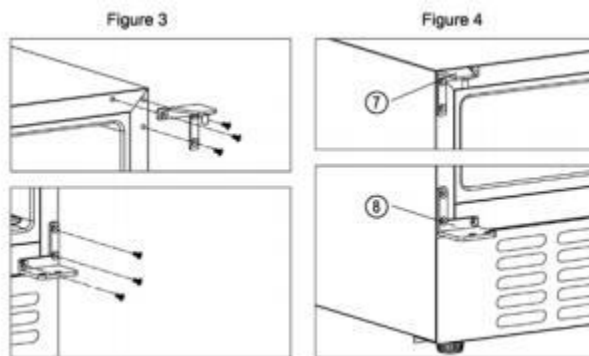

- ❖ Install the top left hinge⑦& left lower hinge⑧ to the left side of the cabinet.(⑦&⑧ delivered in a separated polybag inside the packing carton).[Figure 4]
- ❖ Turn the door⑤ 180 degrees upside down and insert the lower hinge plate③ to the bottom door axis hole. Fit the top door axis hole to the top left hinge⑦ and put lower hinge plate③ slowly on the left lower hinge⑧ and keep the door steady. Screw up the left lower hinge with the plate. Door reversing is finished.

Operation

Start operation

1. Cleaning the compartment

Before power on, clean inside of the appliance and check the drainage pipe in good connection. (For details, please refer to the “Maintenance and cleaning”)

2. Put the appliance still

Before power on, level the appliance on the firm & dry floor for at least 30 minutes.

3. Power on

The appliance start operation and it will cool down inside after 1 hour, otherwise you should check the power connection.

Control panel



All keys would be invalid in lock mode. Please unlock first.

ON/OFF

1. Keep pressing the key 3 seconds, power down, goes to stand-by mode.
2. Keep pressing the key again 3 seconds to return back to normal working.

Light

Press the key, turn on or turn off the LED lights inside. In stand-by mode, the key is invalid.

UP

Press the key once, LED Display in regular flash showing current set temperature. Continue pressing to adjust set temperature, one press increase 1°C. Regular flash quit after 5 seconds detecting no press and new set temperature save. LED display return to show actual temperature inside.



Down

Press the key once, LED Display in regular flash showing current set temperature. Continue pressing to adjust set temperature, one press reduce 1°C. Regular flash quit after 5 seconds detecting no press and new set temperature save. LED display return to show actual temperature inside.



Child Lock (Combination key)

1. Lock: Press both keys at the same time for 3 seconds to lock.
2. Unlock: Press both keys at the same time for 3 seconds to unlock.

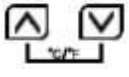

Fahrenheit/Celsius display interchange

Switch temperature display between Fahrenheit and Celsius by pressing both keys.



Attention

1. The ex-factory temperature of this product is 12°C, and the corresponding temperature range needs to be set according to the actual wine.
2. The cooling temperature could be set from **5 to 20°C**.
3. Alarm sound: when the system malfunction occur and alarm sound, press any key on the control panel to cancel the alarm sound.
4. Temperature sensor failure:
When the temperature sensor failures occur, error code displays. E1 for open circuit; E2 for short circuit.

Wine storage

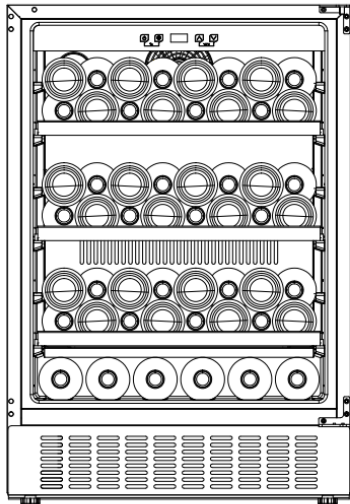

16 bottles

16 bottles

16 bottles

6 bottles

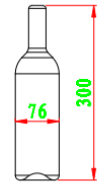
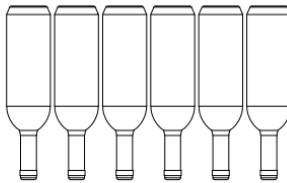
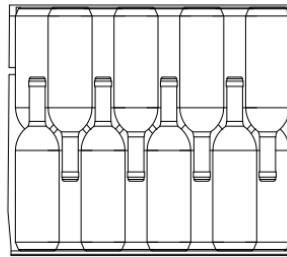

Standard Bordeaux bottle

- ❖ The appliance is equipped with sufficient independent shelf to allow your collection of wine get mature quietly and peacefully.
- ❖ 3 beech wooden shelves loading capacity: **54**bottles. (Standard Bordeaux with 750ml)

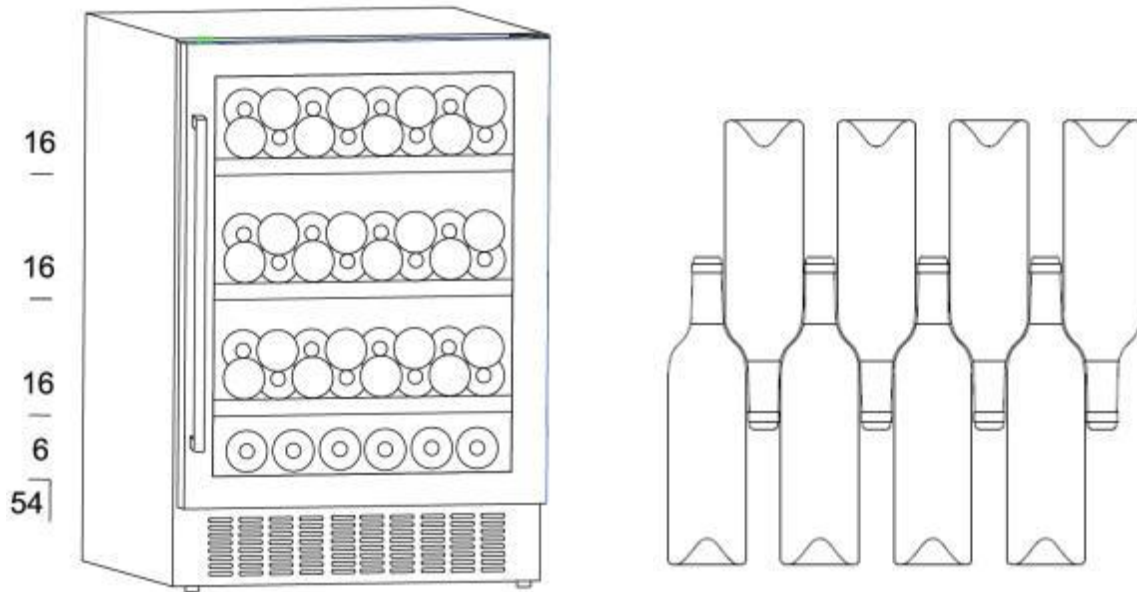

- ❖ Loading capacity will vary in terms of different way of bottle arrangement or different bottle sizes.
- ❖ Each shelf is designed to put on 1 or 2 layers of wine bottles. More than 2 layers of bottle arrangement on one shelf are not recommended.
- ❖ Each shelf can be pulled out partly to store wine bottles easily.
- ❖ The shelf should be avoided in front of the fan as much as possible to avoid blocking the fan and affecting the cooling efficiency.
- ❖ Open the door straight enough before pulling out shelves.
- ❖ If the wine cooler would have no load for a long time, it is recommended to power it off, clean it carefully, and open the door for ventilation.
- ❖ Below table is the recommended temperature for wine storing & drinking:

Red Wine	15-18°C
White Wine	9-14°C
Rose wine	10-11°C
Champagne & sparkling wine	5- 8°C

Troubleshooting

The appliance makes lots of noise?	<ul style="list-style-type: none"> ● Please adjust the front foot, keep the appliance level. ● Please keep the appliance a bit space from walls.
Liquid flowing sound inside the cabinet?	<ul style="list-style-type: none"> ● It is normal because of the refrigerant working inside.
The appliance does not start?	<ul style="list-style-type: none"> ● Make sure the appliance is connected to the power properly. ● Make sure switch on the power. ● The compressor re-starts after 5 minutes for a power cut.
Compressor runs continuously?	<ul style="list-style-type: none"> ● If no cold is being produced, call the after-sale service.
Door does not seal tightly?	<ul style="list-style-type: none"> ● After long time use, the door seal might get stiff & distorted partially. <ol style="list-style-type: none"> 2. Heat the door seal with hot-wind bower or hot towel. 3. The door seal get softened and close the door.
The appliance does not cool sufficiently?	<ul style="list-style-type: none"> ● Please adjust temperature setting. ● Keep the appliance away from sunlight or heat. ● Please do not open the door frequently.
Unpleasant smells inside cabinet?	<ul style="list-style-type: none"> ● A little bit plastic smell for newly-buy appliance is normal and will disappear after a short time. ● Clean the compartment and ventilate it for a few hours
Condensate on the glass door?	<ul style="list-style-type: none"> ● Please do not open the door frequently or for a long time. ● Please do not set the temperature too low. ● High ambient temperature and humidity would cause condensate.
The light is not working?	<ul style="list-style-type: none"> ● Check the power supply first. ● Call the retailer's after-sale service if the light is broken.

Maintenance and cleaning

Cleaning

- Disconnect the appliance before cleaning.
- Clean the appliance with soft cloth or sponge by water.
- Do not use organic solvents, alkaline detergent, boiling water, washing powder or acid liquid etc.
- Do not flush the compartment of the appliance.
- Clean regularly surfaces that can come in contact with accessible drainage systems.

The below items will damage the surface of wine cooler:

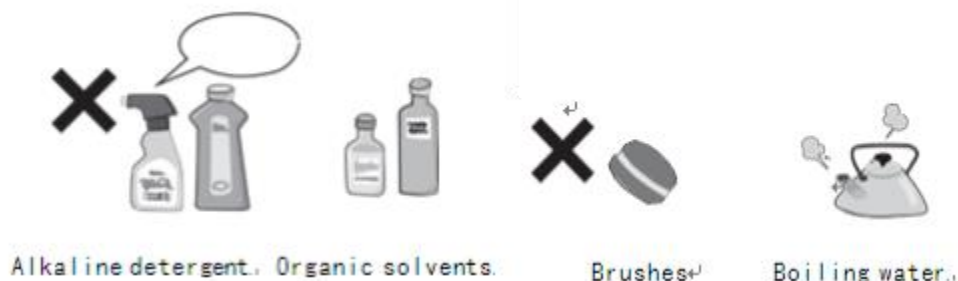

Power cut

Most power cuts could be resolved within a short time. To protect your wines during a power cut, avoid opening the door as much as possible. During very long power cuts, take the necessary measures to protect your wine.

Out of service for long time

Remove all bottles from the appliance, switch off, defrost, clean, dry, and leave the door open to prevent mould developing within the appliance.



If the appliance is disconnected or if there is a power cut, you must wait at least five minutes before re-starting.

Moving the appliance

- Cut off the power supply and unplug the appliance.
- Remove all bottles from the appliance.
- When moving the appliance, do not lean the appliance over 45°.





Technical parameters

Product model	CC145SB-SE
Voltage/frequency	220-240V ~ /50Hz
Refrigerant/weight	R600a/35g
Effective volume	135 L
Loading capacity	54 bottles
Net weight	42 kg
Unit dimension (WxDxH)	595×570×865mm
Packing dimension (WxDxH)	660×625 x 925 mm

Remarks :

1. The Net weight includes shelves and the Unit dimension is without handle on the door.
2. The manufacturer reserves all the rights to change the above parameters without prior notice. Please refer to the nameplate of your appliance.
3. Loading capacity will vary in terms of different way of bottle arrangement or different bottle sizes (standard Bordeaux with 750ml is applied here).